

# Info

## CVD/MKD Linear- Technology Abricht- Towers

CVD/MKD  
Linear Technology  
Dressing Towers

CVD/MKD  
Technologie linéaire  
Tours de Dressage

### FÜR HÖCHSTES PRÄZISES ABRICHTEN

Das industriell hergestellte Abricht-MKD/CVD-Material ist mit seinen Eigenschaften zum perfekten Abrichten optimal für Ihre Schleifscheiben entwickelt worden.

Durch die variable Anordnung der Stäbe kann so ein gezielter Erfolg für Ihr Abrichten erreicht werden.

#### Ihre Merkmale:

- können vollautomatisch eingesetzt werden
- gleichbleibendes wartungsfreies Abrichtverhalten bis zum Verbrauch
- Parallel gesetzte Stäbe für Konturen, Radien, Konkav, Konklave
- Diagonalesetzte Stäbe zum geraden Abrichten. Scheiben werden dadurch schärfer durch Keilwinkel beim Schleifvorgang
- MKD für Sinterkorund- und Silizium-Schleifscheiben
- CVD für Edelmetall-Schleifscheiben
- können als Platte und/oder mit allen gängigen Fassungen hergestellt werden.
- auf Wunsch mit Kühlbohrungen.
- Perfektion des Abrichten durch die geometrische lineare Anordnung der Stäbe

### FOR A DRESSING WITH HIGHEST PRECISION

The industrially manufactured dressing material MKD/CVD and its qualities for a perfect dressing procedure has particularly been developed for your grinding wheels.

By means of a variable arrangement of the rods there is the possibility to obtain concerted results during the dressing process.

#### Their characteristics:

- Can be used in a fully automatic process
- Continuous and maintenance-free dressing behaviour up to the wear
- Rods placed in a parallel way for profiles, radii, convex and concave shapes
- Rods placed in a diagonal way for a straight dressing. The wheels thus become sharper by means of wedge angles during the grinding process.
- MKD for grinding wheels made of fused corundum and silicium
- CVD for grinding wheels made of special fused alumina
- Can be manufactured in form of a plate and/or with all standard mountings
- In case of request, with cooling borings available
- A perfect dressing process due to the geometrically linear arrangement of the rods

### POUR UN DRESSAGE DE HAUTE PRÉCISION

La matière de dressage MKD /CVD fabriquée industriellement a été développée pour les meules. Grâce à sa qualité cette matière est idéale pour un dressage parfait.

Comme les bâtons peuvent être placés d'une manière variable, il est possible d'obtenir ainsi un résultat approprié pendant le dressage.

#### Les données caractéristiques en détail:



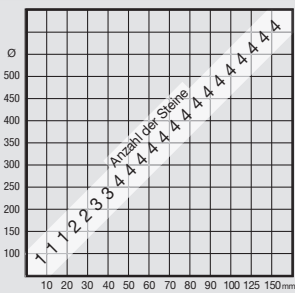





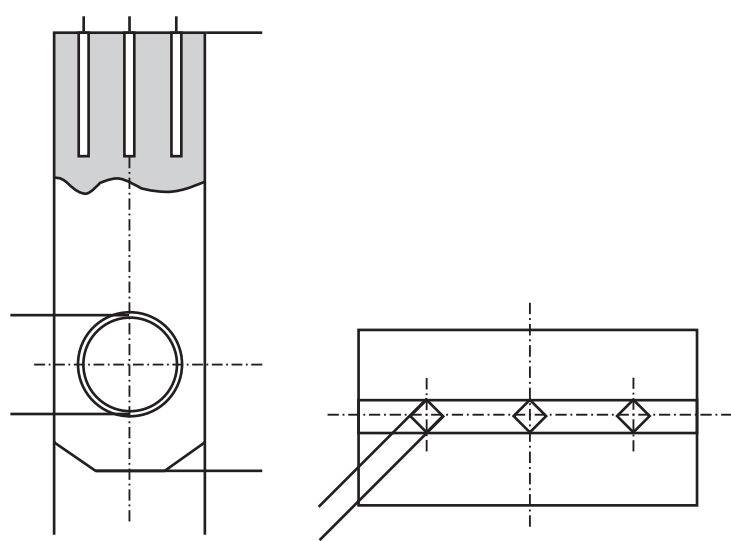







































- Ces outils peuvent être utilisés entièrement automatique
- La qualité du dressage est constante jusqu'à l'usure et ne demande pas de maintenance
- Les bâtons sont placés d'une manière parallèle pour des profils, des rayons, des formes convexes, concaves
- Les bâtons sont placés d'une manière diagonale pour un dressage droit. Les meules deviennent ainsi plus aigües à cause des angles du taillant pendant le traitement
- MKD pour des meules en corindon fritté et en silicium
- CVD pour des meules en corindon raffiné
- Ces outils peuvent être fabriqués comme plaque et/ou avec toutes les montures courantes
- En cas de demande livrable avec des alésages de refroidissement
- Un dressage parfait comme les bâtons sont placés d'une manière géométriquement linéaire



Wahl des Stäbchenquerschnitts ist abhängig von der Scheibenbreite und der Zusammensetzung der Scheibe.

Eigenschaften	1	2	3	4	5	6	7	8	9
Kerndiamant	X	X	X	X	X	X	X	X	X
Industriediamant	X	X	X	X	X	X	X	X	X
Kontinuierliches Abrichten	X	X	X	X	X	X	X	X	X
Präzises Abrichten	X	X	X	X	X	X	X	X	X
Vollautomatisches Abrichten	X	X	X	X	X	X	X	X	X
Grobes Abrichten	X	X	X	X	X	X	X	X	X
Hand Abrichten	X	X	X	X	X	X	X	X	X
PFH Abrichten	X	X	X	X	X	X	X	X	X
Alternatives Abrichten	X	X	X	X	X	X	X	X	X
Gewerben und Schleifen	X	X	X	X	X	X	X	X	X



1 a	Best. Nr. / No.	Anordnung des MKD oder CVD Material	Anzahl	Maße LxBxH	Lieferbare Qualität	Lieferbare Fassungen
<b>CVD/MKD Linear- Technology Abricht- Towers</b>  CVD/MKD Linear Technology Dressing Towers  CVD/MKD Technologie linéaire Tours de Dressage	A 500 P...	Paralell 	1	0,4 x 0,4 x 4	...MKD...	...Platte 10 x 28 x 5 H6,1 10 x 33 x 5 H6,1 20 x 28 x 5 H6,1 20 x 33 x 5 H6,1
	A 501 D...	Diagonal 	1	0,4 x 0,4 x 4		
	A 502 PK...	Paralell + Kühlung 	1	0,4 x 0,4 x 4		
	A 503 DK...	Diagonal + Kühlung 	1	0,4 x 0,4 x 4		
	A 504 P...	Paralell 	2	0,4 x 0,4 x 4		
	A 505 D...	Diagonal 	2	0,4 x 0,4 x 4		
	A 506 PK...	Paralell + Kühlung 	2	0,4 x 0,4 x 4		
	A 507 DK...	Diagonal + Kühlung 	2	0,4 x 0,4 x 4	...MK1	
	A 508 P...	Paralell 	3	0,4 x 0,4 x 4	...CVD...	...MK1 kurz  ...MK0
	A 509 D...	Diagonal 	3	0,4 x 0,4 x 4		
	A 510 PK...	Paralell + Kühlung 	3	0,4 x 0,4 x 4		
	A 511 DK...	Diagonal + Kühlung 	3	0,4 x 0,4 x 4		
	A 512 P...	Paralell 	4	0,4 x 0,4 x 4	...CVD...	...Zylinder alle Abmessungen ab Drm. 6 mm
	A 513 D...	Diagonal 	4	0,4 x 0,4 x 4		
	A 514 PK*...	Paralell + Kühlung 	4	0,4 x 0,4 x 4		
A 515 DK*...	Diagonal + Kühlung 	4	0,4 x 0,4 x 4			
A 516 P...	Paralell 	1	0,6 x 0,6 x 4	...MKD...	...Platte 10 x 28 x 5 H6,1 10 x 33 x 5 H6,1 20 x 28 x 5 H6,1 20 x 33 x 5 H6,1	
A 517 D...	Diagonal 	1	0,6 x 0,6 x 4			
A 518 PK...	Paralell + Kühlung 	1	0,6 x 0,6 x 4			
A 519 DK...	Diagonal + Kühlung 	1	0,6 x 0,6 x 4			
A 520 P...	Paralell 	2	0,6 x 0,6 x 4			
A 521 D...	Diagonal 	2	0,6 x 0,6 x 4			
A 522 PK...	Paralell + Kühlung 	2	0,6 x 0,6 x 4			
A 523 DK...	Diagonal + Kühlung 	2	0,6 x 0,6 x 4	...MK1		
A 524 P...	Paralell 	3	0,6 x 0,6 x 4	...CVD...	...MK1 kurz  ...MK0	
A 525 D...	Diagonal 	3	0,6 x 0,6 x 4			
A 526 PK...	Paralell + Kühlung 	3	0,6 x 0,6 x 4			
A 527 DK...	Diagonal + Kühlung 	3	0,6 x 0,6 x 4			
A 528 P...	Paralell 	4	0,6 x 0,6 x 4	...CVD...	...Zylinder alle Abmessungen ab Drm. 6 mm	
A 529 D...	Diagonal 	4	0,6 x 0,6 x 4			
A 530 PK*...	Paralell + Kühlung 	4	0,6 x 0,6 x 4			
A 531 DK*...	Diagonal + Kühlung 	4	0,6 x 0,6 x 4			
A 532 P...	Paralell 	1	0,8 x 0,8 x 4	...MKD...	...Platte 10 x 28 x 5 H6,1 10 x 33 x 5 H6,1 20 x 28 x 5 H6,1 20 x 33 x 5 H6,1	
A 533 D...	Diagonal 	1	0,8 x 0,8 x 4			
A 534 PK...	Paralell + Kühlung 	1	0,8 x 0,8 x 4			
A 535 DK...	Diagonal + Kühlung 	1	0,8 x 0,8 x 4			
A 536 P...	Paralell 	2	0,8 x 0,8 x 4			
A 537 D...	Diagonal 	2	0,8 x 0,8 x 4			
A 538 PK...	Paralell + Kühlung 	2	0,8 x 0,8 x 4			
A 539 DK...	Diagonal + Kühlung 	2	0,8 x 0,8 x 4	...MK1		
A 540 P...	Paralell 	3	0,8 x 0,8 x 4	...CVD...	...MK1 kurz  ...MK0	
A 541 D...	Diagonal 	3	0,8 x 0,8 x 4			
A 542 PK...	Paralell + Kühlung 	3	0,8 x 0,8 x 4			
A 543 DK...	Diagonal + Kühlung 	3	0,8 x 0,8 x 4			
A 544 P...	Paralell 	4	0,8 x 0,8 x 4	...CVD...	...Zylinder alle Abmessungen ab Drm. 6 mm	
A 545 D...	Diagonal 	4	0,8 x 0,8 x 4			
A 546 PK*...	Paralell + Kühlung 	4	0,8 x 0,8 x 4			
A 547 DK*...	Diagonal + Kühlung 	4	0,8 x 0,8 x 4			

\* Lieferbar Platte  
20 x 28 x 5 und  
20 x 33 x 5

\* Available Plate  
20 x 28 x 5 and  
20 x 33 x 5

\* Livrable Plaque  
20 x 28 x 5 et  
20 x 33 x 5

mit Kühlbohrungen  
für noch längere  
Standzeit

with cooling borings  
for an even longer  
tool life

avec des alésages de  
refroidissement pour  
une plus longue  
durée d'outil